



Low Power Peak EMI Reducing Solution

Features

- Generates an EMI optimized clock signal at the output.
- Integrated loop filter components.
- Operates with a 3.3 / 2.5V Supply.
- Operating current less than 4mA.
- Low power CMOS design.
- Input frequency range: 13MHz to 30MHz for 2.5V.
: 13MHz to 30MHz for 3.3V.
- Generates a 1X low EMI spread spectrum clock of the input frequency.
- Frequency deviation: $\pm 1\%$ (Typ) @16MHz Input Frequency.
- Available in 6-pin TSOT-23, 8-pin SOIC and 8-pin TSSOP packages.

Product Description

The ASM3P2779A is a versatile spread spectrum frequency modulator designed specifically for a wide range of clock frequencies. The ASM3P2779A reduces electromagnetic interference (EMI) at the clock source, allowing system wide reduction of EMI of all clock dependent signals. The ASM3P2779A allows significant system cost savings by reducing the number of circuit board layers ferrite beads, shielding that are traditionally required to pass EMI regulations.

Block Diagram

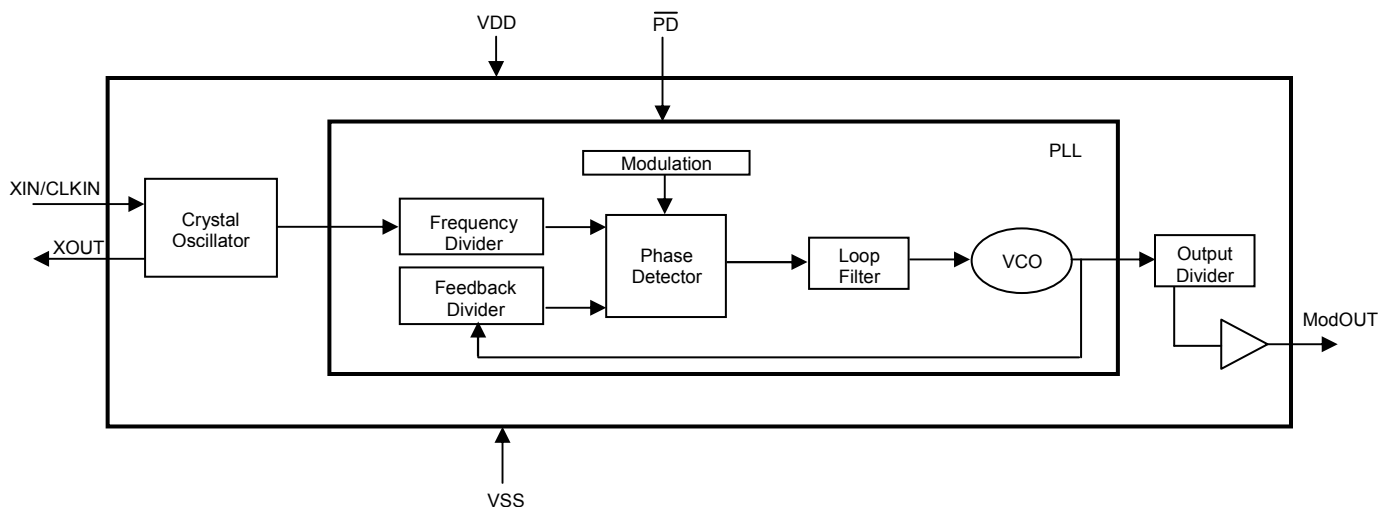

The ASM3P2779A uses the most efficient and optimized modulation profile approved by the FCC and is implemented by using a proprietary all digital method.

The ASM3P2779A modulates the output of a single PLL in order to “spread” the bandwidth of a synthesized clock, and more importantly, decreases the peak amplitudes of its harmonics. This results in significantly lower system EMI compared to the typical narrow band signal produced by oscillators and most frequency generators. Lowering EMI by increasing a signal’s bandwidth is called ‘spread spectrum clock generation’.

Applications

The ASM3P2779A is targeted towards all portable devices with very low power requirements like MP3 players and digital still cameras.

Key Specifications

Description	Specification
Supply voltages	$V_{DD} = 3.3V / 2.5V$
Cycle-to-Cycle Jitter	200 pS (Max)
Output Duty Cycle	45/55% (worst case)
Modulation Rate Equation	$F_{IN}/640$
Frequency Deviation	$\pm 1\%$ (Typ) @ 16MHz



rev 2.9

Pin Configuration (6-pin TSOT- 23 Package)

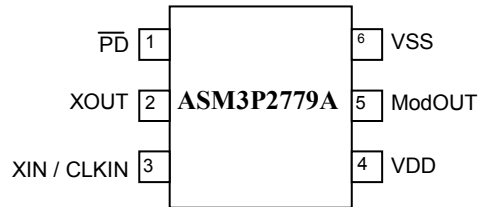

Pin#	Pin Name	Type	Description
1	$\overline{\text{PD}}$	I	Power-down control pin. Pull low to enable power-down mode. Connect to VDD if not used.
2	XOUT	O	Crystal connection. If using an external reference, this pin must be left unconnected.
3	XIN / CLKIN	I	Crystal connection or external reference frequency input. This pin has dual functions. It can be connected either to an external crystal or an external reference clock.
4	VDD	P	Power supply for the entire chip.
5	ModOUT	O	Spread spectrum clock output.
6	VSS	P	Ground connection.



rev 2.9

Pin Configuration (8-pin SOIC and TSSOP Package)

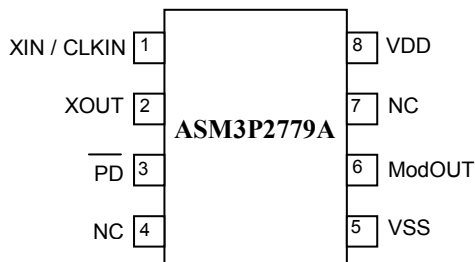

Pin Description

Pin#	Pin Name	Type	Description
1	XIN/CLKIN	I	Crystal connection or external reference frequency input. This pin has dual functions. It can be connected either to an external crystal or an external reference clock.
2	XOUT	O	Crystal connection. If using an external reference, this pin must be left unconnected.
3	$\overline{\text{PD}}$	I	Power-down control pin. Pull low to enable power-down mode. Connect to VDD if not used.
4	NC	–	No connect.
5	VSS	P	Ground connection.
6	ModOUT	O	Spread spectrum clock output.
7	NC	–	No connect.
8	VDD	P	Power supply for the entire chip.

Modulation Profile

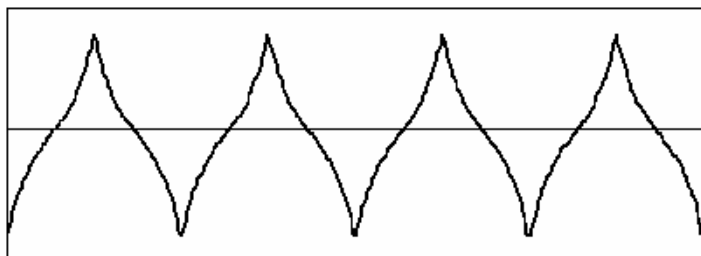

Specifications

Description		Specification
Frequency Range	For 2.5V Supply	13MHz < CLKIN < 30MHz
	For 3.3V Supply	13MHz < CLKIN < 30MHz
Modulation Equation		$F_{IN}/640$
Frequency Deviation		$\pm 1\%$ (Typ) @ 16MHz



rev 2.9

Absolute Maximum Ratings

Symbol	Parameter	Rating	Unit
V_{DD}, V_{IN}	Voltage on any pin with respect to Ground	0.5 to +7.0	V
T_{STG}	Storage temperature	-65 to +125	°C
T_A	Operating temperature	0 to 70	°C
T_s	Max. Soldering Temperature (10 sec)	260	°C
T_J	Junction Temperature	150	°C
T_{DV}	Static Discharge Voltage (As per MIL-STD-883, Method 3015)	2	KV

Note: These are stress ratings only and are not implied for functional use. Exposure to absolute maximum ratings for prolonged periods of time may affect device reliability.

DC Electrical Characteristics for 2.5V Supply

(Test condition: All parameters are measured at room temperature (+25°C) unless otherwise stated)

Symbol	Parameter	Min	Typ	Max	Unit
V_{IL}	Input low voltage	GND - 0.3	–	0.8	V
V_{IH}	Input high voltage	2.0	–	$V_{DD} + 0.3$	V
I_{IL}	Input low current	–	–	-35	μA
I_{IH}	Input high current	–	–	35	μA
I_{XOL}	XOUT output low current (@0.5V, $V_{DD}=2.5V$)	–	3	–	mA
I_{XOH}	XOUT output high current (@1.8V, $V_{DD}=2.5V$)	–	3	–	mA
V_{OL}	Output low voltage ($V_{DD} = 2.5 V, I_{OL} = 8 mA$)	–	–	0.6	V
V_{OH}	Output high voltage ($V_{DD} = 2.5 V, I_{OH} = 8 mA$)	1.8	–	–	V
I_{DD}	Static supply current*	–	–	10	uA
I_{CC}	Dynamic supply current (2.5V, 16MHz and no load)	–	3.0	–	mA
V_{DD}	Operating voltage	2.375	2.5	2.625	V
t_{ON}	Power-up time (first locked cycle after power-up)**	–	–	5	mS
Z_{OUT}	Output impedance	–	50	–	Ω

* XIN /CLKIN pin and \overline{PD} pin are pulled low

** V_{DD} and XIN/CLKIN input are stable, \overline{PD} pin is made high from low.

AC Electrical Characteristics for 2.5V Supply

Symbol	Parameter	Min	Typ	Max	Unit	
CLKIN	Input frequency	13	–	30	MHz	
ModOUT	Output frequency	13	–	30	MHz	
f_d	Frequency Deviation	Input Frequency = 13MHz	–	–	± 1.15	%
		Input Frequency = 30MHz	–	–	± 0.6	
t_{LH}^*	Output rise time (measured from 0.7V to 1.7V)	0.7	1.4	1.8	nS	
t_{HL}^*	Output fall time (measured from 1.7V to 0.7V)	0.4	0.9	1.1	nS	
t_{JC}	Jitter (cycle to cycle)	–	–	200	pS	
t_D	Output duty cycle	45	50	55	%	

* t_{LH} and t_{HL} are measured into a capacitive load of 15pF



rev 2.9

DC Electrical Characteristics for 3.3V Supply

(Test condition: All parameters are measured at room temperature (+ 25°C) unless otherwise stated)

Symbol	Parameter	Min	Typ	Max	Unit
V _{IL}	Input low voltage	GND - 0.3	–	0.8	V
V _{IH}	Input high voltage	2.0	–	V _{DD} + 0.3	V
I _{IL}	Input low current	–	–	-35	μA
I _{IH}	Input high current	–	–	35	μA
I _{XOL}	XOUT output low current (@0.4V, V _{DD} =3.3V)	–	3	–	mA
I _{XOH}	XOUT output high current (@2.5V, V _{DD} =3.3V)	–	3	–	mA
V _{OL}	Output low voltage (V _{DD} = 3.3 V, I _{OL} = 8 mA)	–	–	0.4	V
V _{OH}	Output high voltage (V _{DD} = 3.3 V, I _{OH} = 8 mA)	2.5	–	–	V
I _{DD}	Static supply current*	–	–	10	uA
I _{CC}	Dynamic supply current (3.3V, 16MHz and no load)	–	3.5	–	mA
V _{DD}	Operating voltage	2.7	3.3	3.6	V
t _{ON}	Power-up time (first locked cycle after power-up)**	–	–	5	mS
Z _{OUT}	Output impedance	–	45	–	Ω

* XIN /CLKIN pin and $\overline{\text{PD}}$ pin are pulled low
 ** V_{DD} and XIN/CLKIN input are stable, PD pin is made high from low.

AC Electrical Characteristics for 3.3V Supply

Symbol	Parameter	Min	Typ	Max	Unit
CLKIN	Input frequency	13	–	30	MHz
ModOUT	Output frequency	13	v	30	MHz
f _d	Frequency Deviation				%
	Input Frequency = 13MHz	–	–	±1.15	
	Input Frequency = 30MHz	–	–	± 0.6	
t _{LH} *	Output rise time (measured from 0.8 to 2.0V)	0.5	1.1	1.3	nS
t _{HL} *	Output fall time (measured at 2.0V to 0.8V)	0.3	0.8	0.9	nS
t _{JC}	Jitter (cycle to cycle)	–	–	200	pS
t _D	Output duty cycle	45	50	55	%

*t_{LH} and t_{HL} are measured into a capacitive load of 15pF



rev 2.9

Typical Crystal Oscillator Circuit

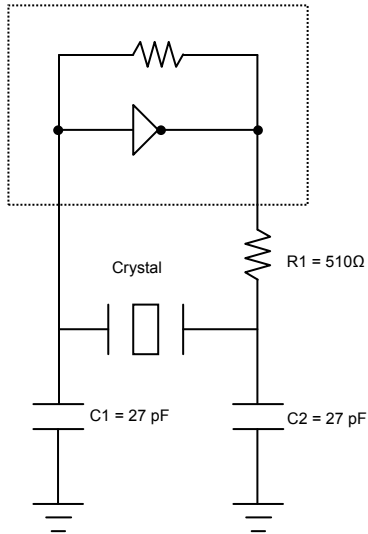

Typical Crystal Specifications

Fundamental AT cut parallel resonant crystal	
Nominal frequency	14.31818 MHz
Frequency tolerance	± 50 ppm or better at 25°C
Operating temperature range	-25°C to +85°C
Storage temperature	-40°C to +85°C
Load capacitance	18pF
Shunt capacitance	7pF maximum
ESR	25 Ω



rev 2.9

Package Information

6-pin TSOT-23 Package

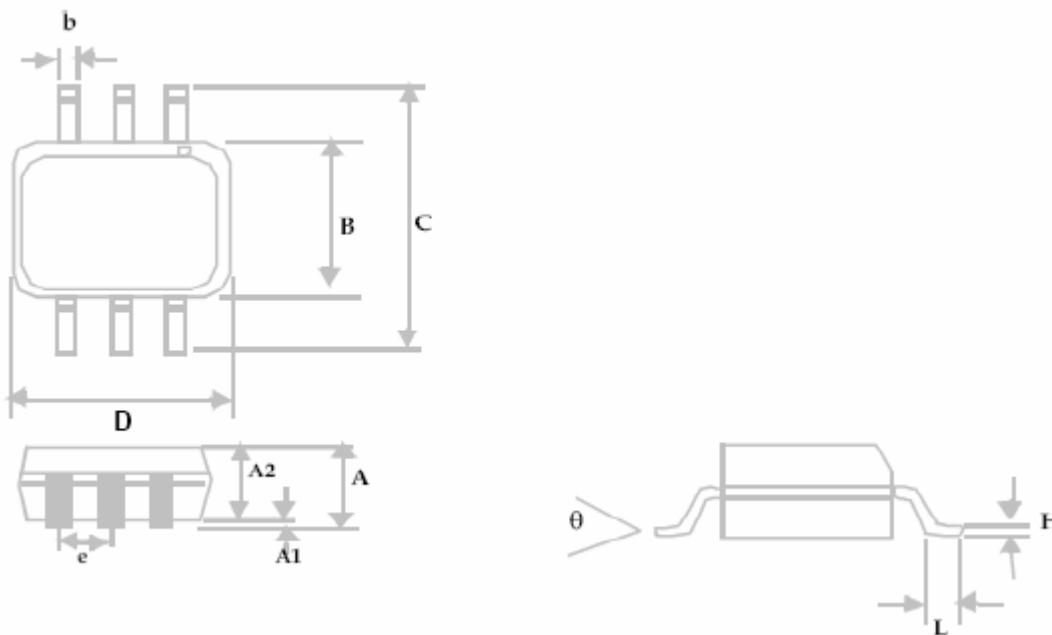

Symbol	Dimensions			
	Inches		Millimeters	
	Min	Max	Min	Max
A		0.04		1.00
A1	0.00	0.004	0.00	0.10
A2	0.033	0.036	0.84	0.90
b	0.012	0.02	0.30	0.50
H	0.005 BSC		0.127 BSC	
D	0.114 BSC		2.90 BSC	
B	0.06 BSC		1.60 BSC	
e	0.0374 BSC		0.950 BSC	
C	0.11 BSC		2.80 BSC	
L	0.0118	0.02	0.30	0.50
θ	0°	4°	0°	4°



8-Pin SOIC Package

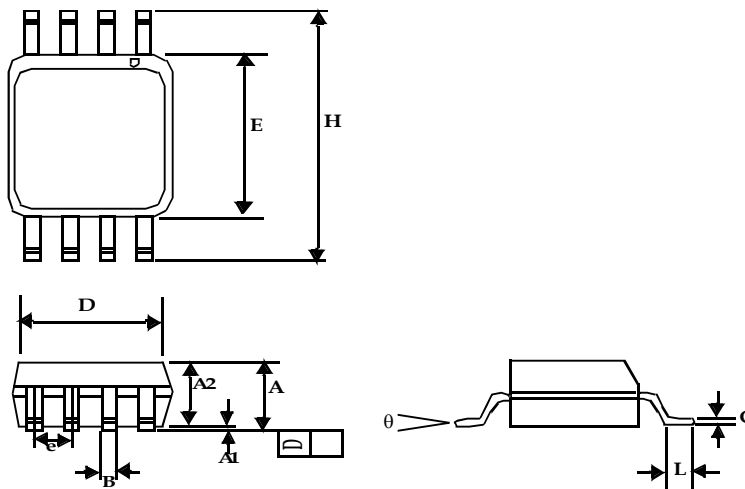

Symbol	Dimensions			
	Inches		Millimeters	
	Min	Max	Min	Max
A1	0.004	0.010	0.10	0.25
A	0.053	0.069	1.35	1.75
A2	0.049	0.059	1.25	1.50
B	0.012	0.020	0.31	0.51
C	0.007	0.010	0.18	0.25
D	0.193 BSC		4.90 BSC	
E	0.154 BSC		3.91 BSC	
e	0.050 BSC		1.27 BSC	
H	0.236 BSC		6.00 BSC	
L	0.016	0.050	0.41	1.27
θ	0°	8°	0°	8°



8-Pin TSSOP Package

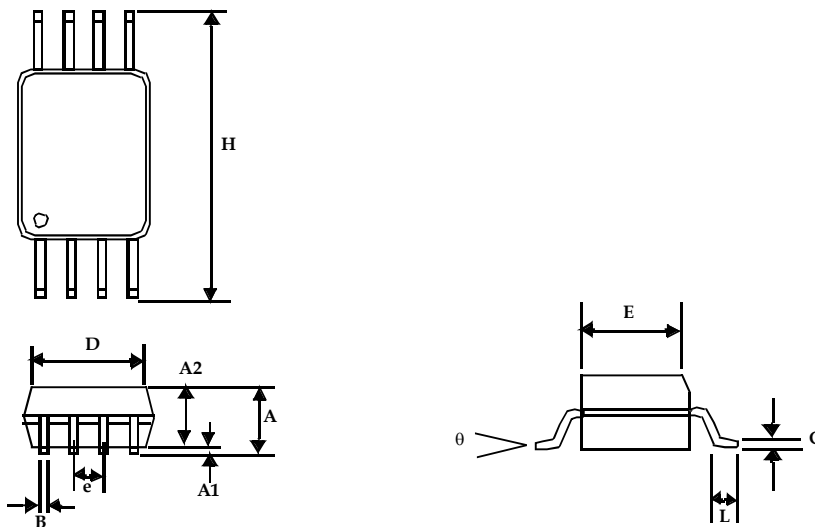

Symbol	Dimensions			
	Inches		Millimeters	
	Min	Max	Min	Max
A		0.043		1.10
A1	0.002	0.006	0.05	0.15
A2	0.033	0.037	0.85	0.95
B	0.008	0.012	0.19	0.30
c	0.004	0.008	0.09	0.20
D	0.114	0.122	2.90	3.10
E	0.169	0.177	4.30	4.50
e	0.026 BSC		0.65 BSC	
H	0.252 BSC		6.40 BSC	
L	0.020	0.028	0.50	0.70
θ	0°	8°	0°	8°



rev 2.9

Ordering Information

Part Number	Marking	Package Type	Temperature
ASM3P2779AF-06OR	A4LL	6-Pin TSOT-23, TAPE & REEL, Pb Free	Commercial
ASM3P2779AF-08TT	3P2779AFT	8-Pin TSSOP, TUBE, Pb Free	Commercial
ASM3P2779AF-08TR	3P2779AFT	8-Pin TSSOP, TAPE & REEL, Pb Free	Commercial
ASM3P2779AF-08ST	3P2779AFS	8-Pin SOIC, TUBE, Pb Free	Commercial
ASM3P2779AF-08SR	3P2779AFS	8-Pin SOIC, TAPE & REEL, Pb Free	Commercial
ASM3P2779A-06OR	A1LL	6-Pin TSOT-23, TAPE & REEL	Commercial
ASM3P2779A-08TT	3P2779AT	8-Pin TSSOP, TUBE	Commercial
ASM3P2779A-08TR	3P2779AT	8-Pin TSSOP, TAPE & REEL	Commercial
ASM3P2779A-08ST	3P2779AS	8-Pin SOIC, TUBE	Commercial
ASM3P2779A-08SR	3P2779AS	8-Pin SOIC, TAPE & REEL	Commercial

Device Ordering Information

A S M 3 P 2 7 7 9 A F - 0 8 T R

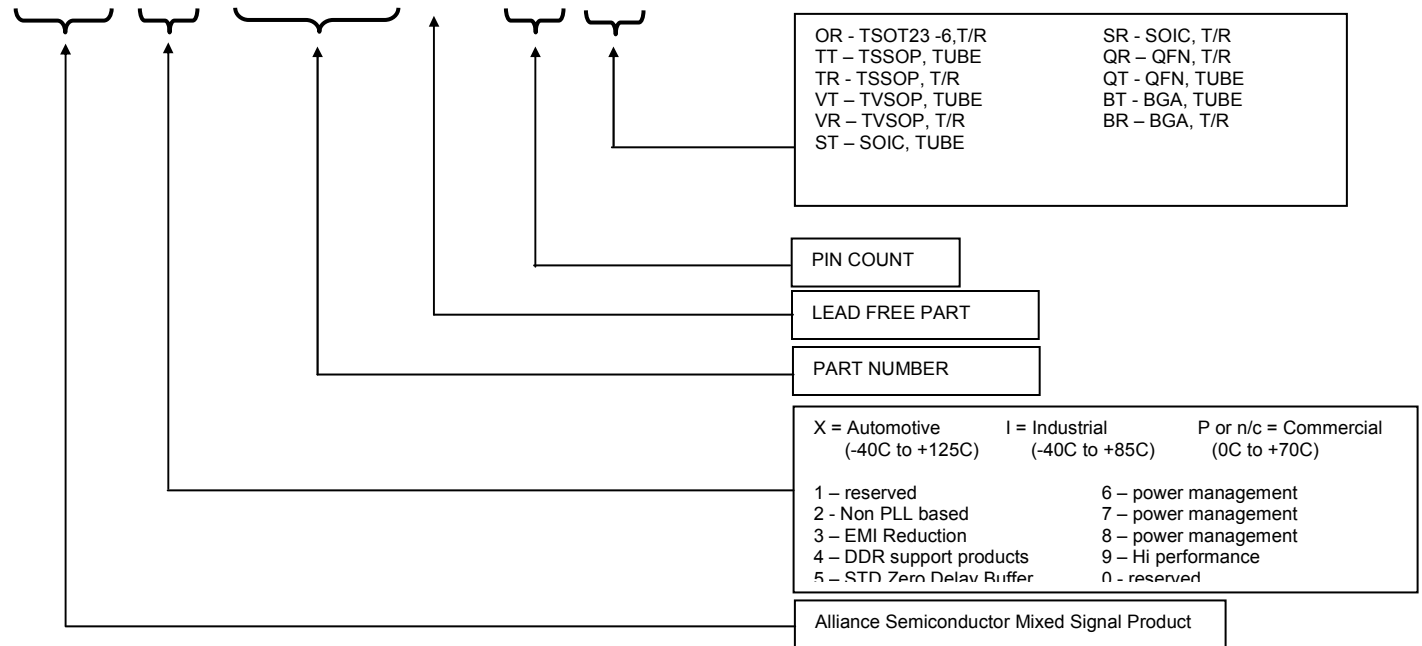

Licensed under U.S Patent Nos 5,488,627 and 5,631,921



Alliance Semiconductor Corporation
2595, Augustine Drive,
Santa Clara, CA 95054
Tel# 408-855-4900
Fax: 408-855-4999
www.alsc.com

Copyright © Alliance Semiconductor
All Rights Reserved
Preliminary Information
Part Number: ASM3P2779A
Document Version: v2.9

Note: This product utilizes US Patent # 6,646,463 Impedance Emulator Patent issued to Alliance Semiconductor, dated 11-11-2003

© Copyright 2003 Alliance Semiconductor Corporation. All rights reserved. Our three-point logo, our name and Intelliwatt are trademarks or registered trademarks of Alliance. All other brand and product names may be the trademarks of their respective companies. Alliance reserves the right to make changes to this document and its products at any time without notice. Alliance assumes no responsibility for any errors that may appear in this document. The data contained herein represents Alliance's best data and/or estimates at the time of issuance. Alliance reserves the right to change or correct this data at any time, without notice. If the product described herein is under development, significant changes to these specifications are possible. The information in this product data sheet is intended to be general descriptive information for potential customers and users, and is not intended to operate as, or provide, any guarantee or warranty to any user or customer. Alliance does not assume any responsibility or liability arising out of the application or use of any product described herein, and disclaims any express or implied warranties related to the sale and/or use of Alliance products including liability or warranties related to fitness for a particular purpose, merchantability, or infringement of any intellectual property rights, except as express agreed to in Alliance's Terms and Conditions of Sale (which are available from Alliance). All sales of Alliance products are made exclusively according to Alliance's Terms and Conditions of Sale. The purchase of products from Alliance does not convey a license under any patent rights, copyrights; mask works rights, trademarks, or any other intellectual property rights of Alliance or third parties. Alliance does not authorize its products for use as critical components in life-supporting systems where a malfunction or failure may reasonably be expected to result in significant injury to the user, and the inclusion of Alliance products in such life-supporting systems implies that the manufacturer assumes all risk of such use and agrees to indemnify Alliance against all claims arising from such use.