



## Low Power Mobile VGA EMI Reduction IC

### Features

- FCC approved method of EMI attenuation
- Provides up to 15dB EMI reduction
- Generates a low EMI spread spectrum clock and a non-spread Reference Clock of the input frequency
- Optimized for frequency range from 20MHz to 40MHz
- Internal loop filter minimizes external components and board space
- Down Spread Deviation: -1.25%
- Low inherent Cycle-to-Cycle jitter
- 3.3V Operating Voltage
- CMOS/TTL compatible inputs and outputs
- Low power CMOS design
- Supports notebook VGA and other LCD timing controller applications
- Power Down function for mobile application
- Products are available for industrial temperature range.
- Available in 8 pin SOIC and TSSOP Packages

### Functional Description

The ASM3P1819N is a versatile spread spectrum frequency modulator designed specifically for a wide range of input clock frequencies from 20 to 40MHz. The ASM3P1819N can generate an EMI reduced clock from crystal, ceramic resonator, or system clock.

The ASM3P1819N reduces electromagnetic interference (EMI) at the clock source, allowing a system wide EMI reduction for all the down stream clocks and data dependent signals. The ASM3P1819N allows significant system cost savings by reducing the number of circuit board layers, ferrite beads, shielding, and other passive components that are traditionally required to pass EMI regulations.

The ASM3P1819N modulates the output of a single PLL in order to “spread” the bandwidth of a synthesized clock, thereby decreasing the peak amplitude of its harmonics. This result in significantly lower system EMI compared to the typical narrow band signal produced by oscillators and most clock generators.

Lowering EMI by increasing a signal’s bandwidth is called “spread spectrum clock generation”. The ASM3P1819N uses the most efficient and optimized modulation profile approved by the FCC and is implemented by using a proprietary all digital method

### Applications

The ASM3P1819N is targeted towards EMI management for memory and LVDS interfaces in mobile graphic chipsets and high-speed digital applications such as PC peripheral devices, consumer electronics and embedded controller system.

### Block Diagram

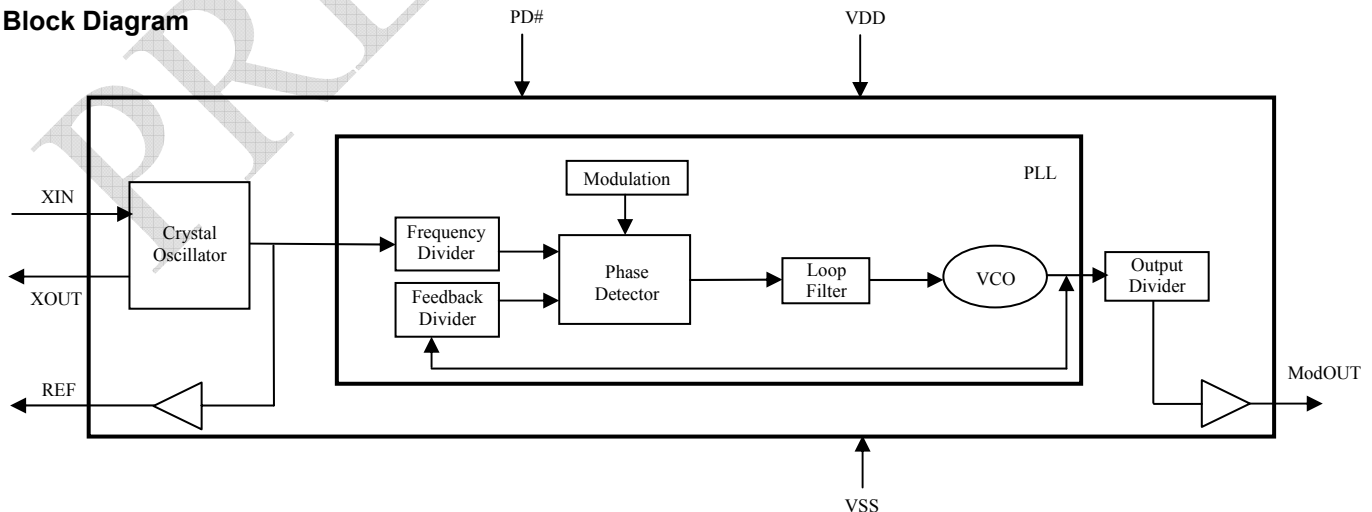



rev 0.2

## Pin Configuration

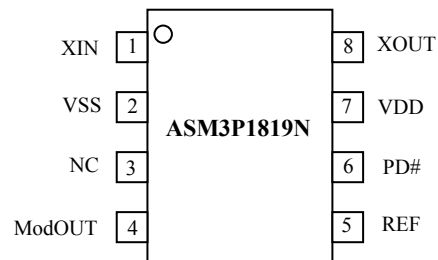

## Pin Description

Pin#	Pin Name	Type	Description
1	XIN	I	Connect to externally generated Clock signal or Crystal.
2	VSS	P	Ground Connection. Connect to system ground.
3	NC	-	No Connect.
4	ModOUT	O	Spread spectrum clock output.
5	REF	O	Non-modulated Reference clock output of the input frequency.
6	PD#	I	Power down control pin. Pull LOW to enable Power-Down mode. This pin has an internal pull-up resistor.
7	VDD	P	Connect to +3.3V.
8	XOUT	I	Connect to crystal. No connect if externally generated clock signal is used.

## Absolute Maximum Ratings

Symbol	Parameter	Rating	Unit
VDD, V <sub>IN</sub>	Voltage on any pin with respect to Ground	-0.5 to +7.0	V
T <sub>STG</sub>	Storage temperature	-65 to +125	°C
T <sub>A</sub>	Operating temperature	0 to 70	°C
T <sub>s</sub>	Max. Soldering Temperature (10 sec)	260	°C
T <sub>J</sub>	Junction Temperature	150	°C
T <sub>DV</sub>	Static Discharge Voltage (As per JEDEC STD22- A114-B)	2	KV

Note: These are stress ratings only and are not implied for functional use. Exposure to absolute maximum ratings for prolonged periods of time may affect device reliability.

## Output Frequency and Modulation Rate

Input Frequency Range (MHz)	Output Frequency Range (MHz)	Modulation Rate	Spread Deviation (%)
20 to 40	20 to 40	Input Frequency / 512	-1.25



## rev 0.2

**DC Electrical Characteristics**

(Test condition: All parameters are measured at room temperature (+25°C) unless otherwise stated)

Symbol	Parameter	Min	Typ	Max	Unit
V <sub>IL</sub>	Input Low voltage	VSS – 0.3	-	0.8	V
V <sub>IH</sub>	Input High voltage	2.0	-	VDD + 0.3	V
I <sub>IL</sub>	Input Low current	-	-	-20.0	μA
I <sub>IH</sub>	Input High current	-	-	1.0	μA
I <sub>XOL</sub>	X <sub>OUT</sub> Output low current @ 0.4V, VDD = 3.3V	-	3	-	mA
I <sub>XOH</sub>	X <sub>OUT</sub> Output high current @ 2.5V, VDD = 3.3V	-	3	-	mA
V <sub>OL</sub>	Output Low voltage VDD = 3.3V, I <sub>OL</sub> = 20mA	-	-	0.4	V
V <sub>OH</sub>	Output High voltage VDD = 3.3V, I <sub>OH</sub> = 20mA	2.5	-	-	V
I <sub>CC</sub>	Dynamic Supply current 3.3V and 10pF probe loading	7.1 f <sub>IN - min</sub>	-	26.9 f <sub>IN - max</sub>	mA
I <sub>DD</sub>	Static Supply current	-	4.5	-	mA
VDD	Operating Voltage	-	3.3	-	V
t <sub>ON</sub>	Power up time (First locked clock cycle after power up)	-	0.18	-	mS
Z <sub>OUT</sub>	Clock Output impedance	-	50	-	Ω

**AC Electrical Characteristics**

Symbol	Parameter	Min	Typ	Max	Unit
f <sub>IN</sub>	Input Frequency	20	-	40	MHz
f <sub>OUT</sub>	Output Frequency	20	-	40	MHz
t <sub>LH</sub> <sup>1</sup>	Output Rise time ( Measured from 0.8V to 2.0V )	-	0.69	-	nS
t <sub>HL</sub> <sup>1</sup>	Output Fall time ( Measured from 2.0V to 0.8V )	-	0.66	-	nS
t <sub>JC</sub>	Jitter (Cycle to Cycle)	-200	-	200	pS
t <sub>D</sub>	Output Duty cycle	45	50	55	%

Note: 1. t<sub>LH</sub> and t<sub>HL</sub> are measured into a capacitive load of 15pF



8-Pin (150-mil) SOIC Package

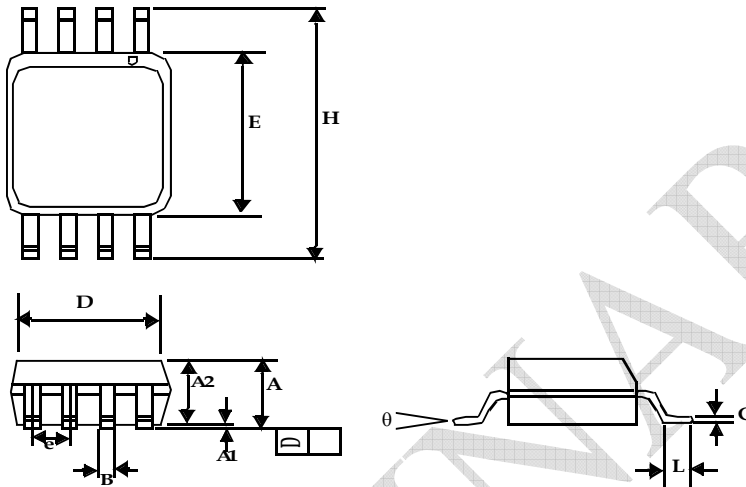

Symbol	Dimensions			
	Inches		Millimeters	
	Min	Max	Min	Max
A1	0.004	0.010	0.10	0.25
A	0.053	0.069	1.35	1.75
A2	0.049	0.059	1.25	1.50
B	0.012	0.020	0.31	0.51
C	0.007	0.010	0.18	0.25
D	0.193 BSC		4.90 BSC	
E	0.154 BSC		3.91 BSC	
e	0.050 BSC		1.27 BSC	
H	0.236 BSC		6.00 BSC	
L	0.016	0.050	0.41	1.27
θ	0°	8°	0°	8°

Note: Controlling dimensions are millimeters  
SOIC – 0.074 grams unit weight



8-lead Thin Shrunk Small Outline Package (4.40-MM Body)

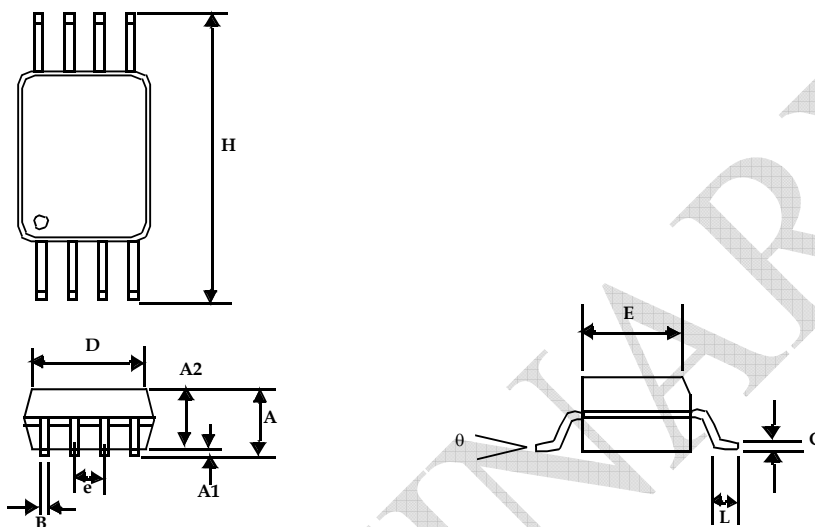

Symbol	Dimensions			
	Inches		Millimeters	
	Min	Max	Min	Max
A		0.043		1.10
A1	0.002	0.006	0.05	0.15
A2	0.033	0.037	0.85	0.95
B	0.008	0.012	0.19	0.30
c	0.004	0.008	0.09	0.20
D	0.114	0.122	2.90	3.10
E	0.169	0.177	4.30	4.50
e	0.026 BSC		0.65 BSC	
H	0.252 BSC		6.40 BSC	
L	0.020	0.028	0.50	0.70
$\theta$	0°	8°	0°	8°

Note: Controlling dimensions are millimeters  
 TSSOP – 0.0325 grams unit weight



rev 0.2

Ordering Information

Part number	Marking	Package Configuration	Temperature Range
ASM3P1819N -08-ST	3P1819N	8-Pin SOIC, Tube	Commercial
ASM3P1819N -08-SR	3P1819N	8-Pin SOIC, Tape and Reel	Commercial
ASM3P1819NF-08-ST	3P1819NF	8-Pin SOIC, Tube, Pb Free	Commercial
ASM3P1819NF-08-SR	3P1819NF	8-Pin SOIC, Tape and Reel, Pb Free	Commercial
ASM3P1819NG-08-ST	3P1819NG	8-Pin SOIC, Tube, Green	Commercial
ASM3P1819NG-08-SR	3P1819NG	8-Pin SOIC, Tape and Reel, Green	Commercial
ASM3I1819N -08-ST	3I1819N	8-Pin SOIC, Tube	Industrial
ASM3I1819N -08-SR	3I1819N	8-Pin SOIC, Tape and Reel	Industrial
ASM3I1819NF-08-ST	3I1819NF	8-Pin SOIC, Tube, Pb Free	Industrial
ASM3I1819NF-08-SR	3I1819NF	8-Pin SOIC, Tape and Reel, Pb Free	Industrial
ASM3I1819NG-08-ST	3I1819NG	8-Pin SOIC, Tube, Green	Industrial
ASM3I1819NG-08-SR	3I1819NG	8-Pin SOIC, Tape and Reel, Green	Industrial
ASM3P1819N -08-TT	3P1819N	8-Pin TSSOP, Tube	Commercial
ASM3P1819N -08-TR	3P1819N	8-Pin TSSOP, Tape and Reel	Commercial
ASM3P1819NF-08-TT	3P1819NF	8-Pin TSSOP, Tube, Pb Free	Commercial
ASM3P1819NF-08-TR	3P1819NF	8-Pin TSSOP, Tape and Reel, Pb Free	Commercial
ASM3P1819NG-08-TT	3P1819NG	8-Pin TSSOP, Tube, Green	Commercial
ASM3P1819NG-08-TR	3P1819NG	8-Pin TSSOP, Tape and Reel, Green	Commercial
ASM3I1819N -08-TT	3I1819N	8-Pin TSSOP, Tube	Industrial
ASM3I1819N -08-TR	3I1819N	8-Pin TSSOP, Tape and Reel	Industrial
ASM3I1819NF-08-TT	3I1819NF	8-Pin TSSOP, Tube, Pb Free	Industrial
ASM3I1819NF-08-TR	3I1819NF	8-Pin TSSOP, Tape and Reel, Pb Free	Industrial
ASM3I1819NG-08-TT	3I1819NG	8-Pin TSSOP, Tube, Green	Industrial
ASM3I1819NG-08-TR	3I1819NG	8-Pin TSSOP, Tape and Reel, Green	Industrial

Device Ordering Information

A S M 3 P 1 8 1 9 N F - 0 8 - S R

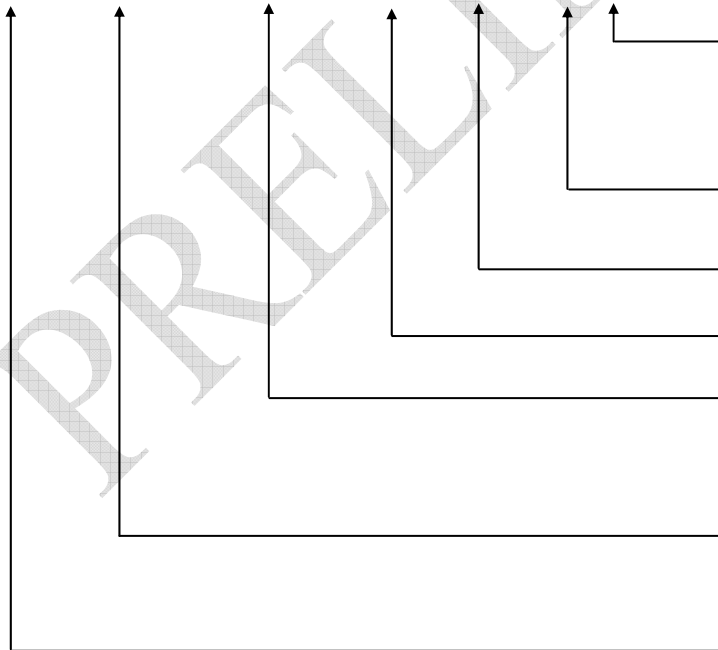

R = Tape & reel, T = Tube or Tray	
O = SOT	U = MSOP
S = SOIC	E = TQFP
T = TSSOP	L = LQFP
A = SSOP	U = MSOP
V = TVSOP	P = PDIP
B = BGA	D = QSOP
Q = QFN	X = SC-70
DEVICE PIN COUNT	
F = LEAD FREE AND RoHS COMPLIANT PART G = GREEN PACKAGE	
PART NUMBER	
X= Automotive (-40C to +125C)    I= Industrial (-40C to +85C)    P or n/c = Commercial (0C to +70C)	
1 = Reserved	6 = Power Management
2 = Non PLL based	7 = Power Management
3 = EMI Reduction	8 = Power Management
4 = DDR support products	9 = Hi Performance
5 = STD Zero Delav Buffer	0 = Reserved
ALLIANCE SEMICONDUCTOR MIXED SIGNAL PRODUCT	

Licensed under US patent #5,488,627, #6,646,463 and #5,631,920



Alliance Semiconductor Corporation  
2575 Augustine Drive,  
Santa Clara, CA 95054  
Tel# 408-855-4900  
Fax: 408-855-4999  
www.alsc.com

Copyright © Alliance Semiconductor  
All Rights Reserved  
Part Number: ASM3P1819N  
Document Version: 0.2

Note: This product utilizes US Patent # 6,646,463 Impedance Emulator Patent issued to Alliance Semiconductor, dated 11-11-2003

© Copyright 2003 Alliance Semiconductor Corporation. All rights reserved. Our three-point logo, our name and Intelliwatt are trademarks or registered trademarks of Alliance. All other brand and product names may be the trademarks of their respective companies. Alliance reserves the right to make changes to this document and its products at any time without notice. Alliance assumes no responsibility for any errors that may appear in this document. The data contained herein represents Alliance's best data and/or estimates at the time of issuance. Alliance reserves the right to change or correct this data at any time, without notice. If the product described herein is under development, significant changes to these specifications are possible. The information in this product data sheet is intended to be general descriptive information for potential customers and users, and is not intended to operate as, or provide, any guarantee or warranty to any user or customer. Alliance does not assume any responsibility or liability arising out of the application or use of any product described herein, and disclaims any express or implied warranties related to the sale and/or use of Alliance products including liability or warranties related to fitness for a particular purpose, merchantability, or infringement of any intellectual property rights, except as express agreed to in Alliance's Terms and Conditions of Sale (which are available from Alliance). All sales of Alliance products are made exclusively according to Alliance's Terms and Conditions of Sale. The purchase of products from Alliance does not convey a license under any patent rights, copyrights; mask works rights, trademarks, or any other intellectual property rights of Alliance or third parties. Alliance does not authorize its products for use as critical components in life-supporting systems where a malfunction or failure may reasonably be expected to result in significant injury to the user, and the inclusion of Alliance products in such life-supporting systems implies that the manufacturer assumes all risk of such use and agrees to indemnify Alliance against all claims arising from such use.